



WiMAX Technology can offer Coverage in Both LOS and NLOS Conditions

Amir Hossein Dehghan
Department of Computer Science
University of Pune, PUCSD.
Pune, Maharashtra, India
Dehgan.amir@gmail.com

Dr. V.P. Pawar
Director of Institute of Computer Application
Siddhant Institute of Computer Application
Pune, Maharashtra, India
drvrushsen_pawar@rediffmail.com

Abstract-- WiMAX technology can provide coverage in LOS and NLOS conditions, NLOS has many implementation advantages that enable operators to deliver broadband data to wide range of customer, WiMAX technology has many advantages that allow it to provide NLOS solutions, with essential feature such as OFDM technology, adaptive modulation and error correction.

WiMAX has many optional features, such as ARQ, sub-channeling, diversity and space-time coding, It will prove invaluable to operators wishing to provide quality and performance that rivals wireline technology.

WiMAX's advanced technology provides the best of both worlds' large coverage distances of up to 50 kilometers under LOS conditions and typical cell radii of up to 5 miles/8 km under NLOS conditions.

Keywords: LOS, NLOS, WiMax, CPE, Base Station, OFDM, Sub-Channelization, Directional antennas

I. INTRODUCTION

Service operators face some tough decisions as they witness a rising demand for “anywhere, anytime” broadband access. Service-operators sense that there is a real business opportunity to provide a substantial increase to the all-important average revenue per user (ARPU). However, when considering the implementation aspect, service providers find the technological landscape dotted with options, trends, and hype. Many technologies, backed by strong vendors and consortiums are vying for the service providers' attention. In addition, many vendors, having invested considerable amount of resources and money in the different technologies, are loudly promoting their respective technologies.

This paper examines the different technological options facing a service provider considering deploying a personal, mobile, broadband access network. The paper provides a high level comparison of commonalities and differences of these various technologies. It focuses on high capacity technologies comparing WiMAX 4G technology and the different 3G options, 1xEVDO, HSDPA / HSUPA, WCDMA, CDMA2000 3G FDD based networks, and where possible, the “over the horizon” 3GPP-LTE.

II. NLOS VERSUS LOS PROPAGATION

The radio channel of a wireless communication system is often described as being either LOS or NLOS. In a LOS link, a signal travels over a direct and unobstructed path from the transmitter to the receiver. A LOS link requires that most of the first Fresnel zone is free of any obstruction, see Figure 1 if this criterion is not met then there is a significant reduction in signal strength, see [Ref 1]. The Fresnel clearance required depends on the operating frequency and the distance between the transmitter and receiver locations.

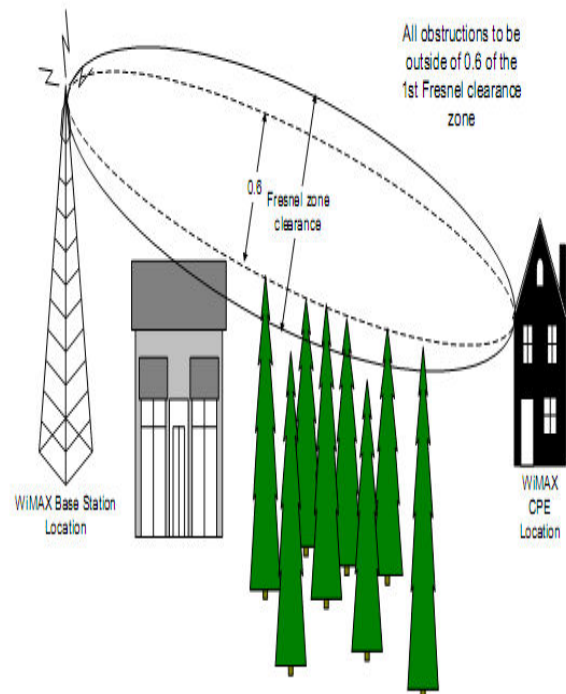

Figure.1. LOS Fresnel zone

In a NLOS link, a signal reaches the receiver through reflections, scattering, and diffractions. The signals arriving at the receiver consists of components from the direct path, multiple reflected paths, scattered energy, and diffracted propagation paths. These signals have different delay spreads, attenuation, polarizations, and stability relative to the direct path.

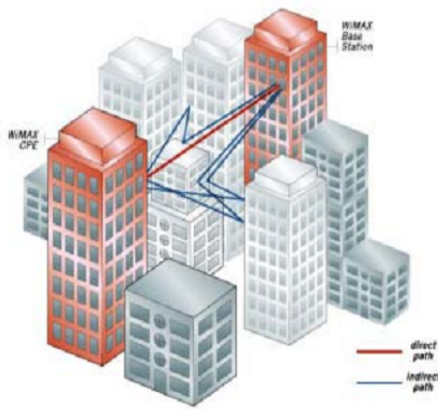

Figure .2. NLOS propagation

The multi path phenomena can also cause the polarization of the signal to be changed. Thus using polarization as a means of frequency re-use, as is normally done in LOS deployments can be problematic in NLOS applications.

How a radio system uses these multi path signals to an advantage is the key to providing service in NLOS conditions. A product that merely increases power to penetrate obstructions (sometimes called “near line of sight”) is not NLOS technology because this approach still relies on a strong direct path without using energy present in the indirect signals. Both LOS and NLOS coverage conditions are governed by the propagation characteristics of their environment, path loss, and radio link budget.

There are several advantages that make NLOS deployments desirable. For instance, strict planning requirements and antenna height restrictions often do not allow the antenna to be positioned for LOS. For large-scale contiguous cellular deployments, where frequency re-use is critical, lowering the antenna is advantageous to reduce the co channel interference between adjacent cell sites. This often forces the base stations to operate in NLOS conditions. LOS systems cannot reduce antenna heights because doing so would impact the required direct view path from the CPE to the Base Station.

NLOS technology also reduces installation expenses by making under-the-eaves CPE installation a reality and easing the difficulty of locating adequate CPE mounting locations. The technology also reduces the need for pre installation site surveys and improves the accuracy of NLOS planning tools.

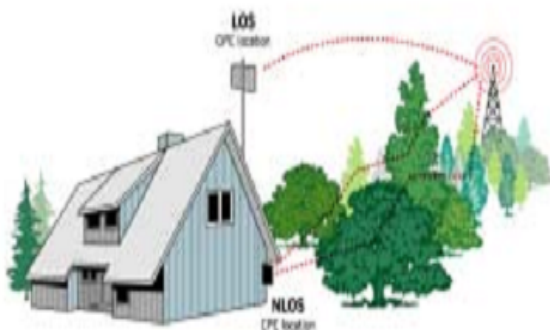

Figure 3. NLOS CPE location

The NLOS technology and the enhanced features in

WiMAX make it possible to use indoor customer premise equipment (CPE). This has two main challenges; firstly overcoming the building penetration losses and secondly, covering reasonable distances with the lower transmit powers and antenna gains that are usually associated with indoor CPEs. WiMAX makes this possible, and the NLOS coverage can be further improved by leveraging some of WiMAX’s optional capabilities. This is elaborated more in the following sections.

III. NLOS TECHNOLOGY SOLUTIONS

- [a] WiMAX technology, solves or mitigates the problems resulting from NLOS conditions by using:
- [b] OFDM technology.
- [c] Sub-Channelization.
- [d] Directional antennas.
- [e] Transmit and receive diversity.
- [f] Adaptive modulation.
- [g] Error correction techniques.
- [h] Power control.

A. *Ofdm Technology*

Orthogonal frequency division multiplexing (OFDM) technology provides operators with an efficient means to overcome the challenges of NLOS propagation. The WiMAX OFDM waveform offers the advantage of being able to operate with the larger delay spread of the NLOS environment. By virtue of the OFDM symbol time and use of a cyclic prefix, the OFDM waveform eliminates the inter-symbol interference (ISI) problems and the complexities of adaptive equalization. Because the OFDM waveform is composed of multiple narrowband orthogonal carriers, selective fading is localized to a subset of carriers that are relatively easy to equalize.

An example is shown below as a comparison between an OFDM signal and a single carrier signal, with the information being sent in parallel for OFDM and in series for single carrier.

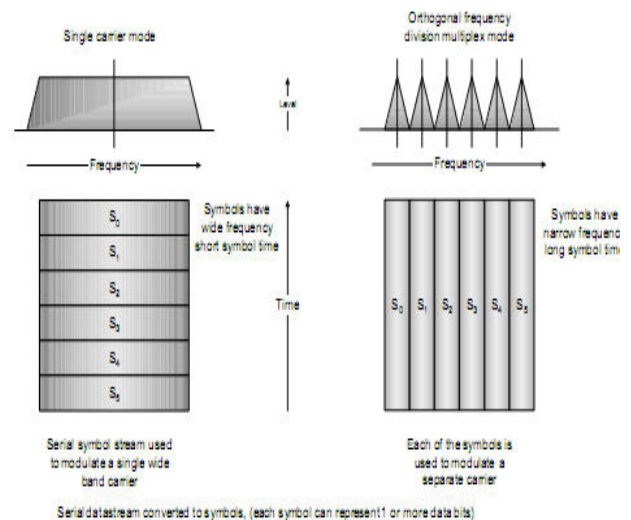

Figure 4. Single carrier and OFDM

The ability to overcome delay spread, multi-path, and ISI in an efficient manner allows for higher data rate throughput. As an example it is easier to equalize the individual OFDM carriers than it is to equalize the broader single carrier signal.

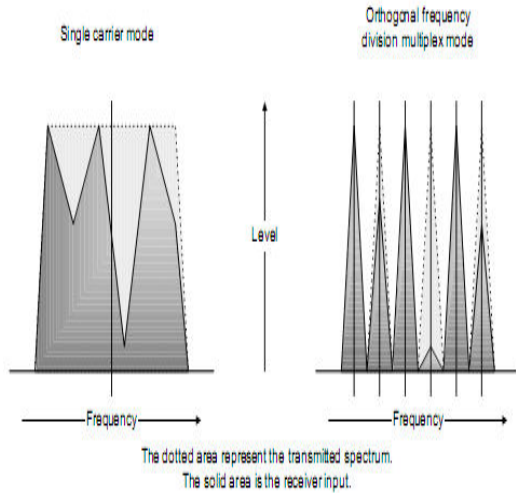

Figure. 5. Single carrier and OFDM received signals

For all of these reasons recent international standards such as those set by IEEE 802.16, ETSI BRAN, and ETRI, have established OFDM as the preferred technology of choice.

B. Sub Channelization

Sub Channelization in the uplink is an option within WiMAX. Without sub channelization, regulatory restrictions and the need for cost effective CPEs, typically cause the link budget to be asymmetrical, this causes the system range to be up link limited. Sub channeling enables the link budget to be balanced such that the system gains are similar for both the up and down links. Sub channeling concentrates the transmit power into fewer OFDM carriers; this is what increases the system gain that can either be used to extend the reach of the system, overcome the building penetration losses, and or reduce the power consumption of the CPE. The use of sub channeling is further expanded in orthogonal frequency division multiple access (OFDMA) to enable a more flexible use of resources that can support nomadic or mobile operation.

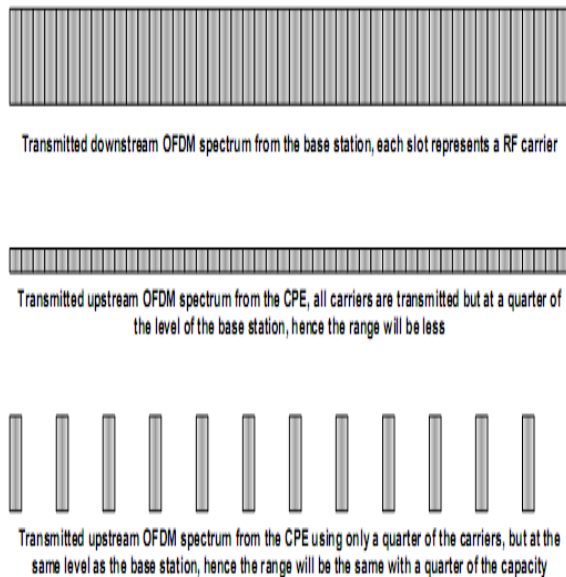

Figure. 6. The effect of sub-channelization

C. Antennas For Fixed Wireless Applications

Directional antennas increase the fade margin by adding more gain. This increases the link availability as shown by K-factor comparisons between directional and Omni-directional antennas [Ref 2]. Delay spread is further reduced by directional antennas at both the Base Station and CPE [Ref 3]. The antenna pattern suppresses any multi-path signals that arrive in the side lobes and back lobes. The effectiveness of these methods has been proven and demonstrated in successful deployments, in which the service operates under significant NLOS fading.

Adaptive antenna systems (AAS) are an optional part of the 802.16 standard. These have beam forming properties that can steer their focus to a particular direction or directions. This means that while transmitting, the signal can be limited to the required direction of the receiver; like a spotlight. Conversely when receiving, the AAS can be made to focus only in the direction from where the desired signal is coming from. They also have the property of suppressing co-channel interference from other locations. AASs are considered to be future developments that could eventually improve the spectrum re-use and capacity of a WiMAX network.

D. Transmit And Receive Diversity

Diversity schemes are used to take advantage of multi-path and reflections signals that occur in NLOS conditions. Diversity is an optional feature in WiMAX. The diversity algorithms offered by WiMAX in both the transmitter and receiver increase the system availability. The WiMAX transmit diversity option uses space time coding to provide transmit source independence; this reduces the fade margin requirement and combats interference. For receive diversity, various combining techniques are exist to improve the availability of the system. For instance, maximum ratio combining (MRC) takes advantage of two separate receive chains to help overcome fading and reduce path loss. Diversity has proven to be an effective tool for coping with the challenges of NLOS propagation.

E. Adaptive Modulation

Adaptive modulation allows the WiMAX system to adjust the signal modulation scheme depending on the signal to noise ratio (SNR) condition of the radio link. When the radio link is high in quality, the highest modulation scheme is used, giving the system more capacity. During a signal fade, the WiMAX system can shift to a lower modulation scheme to maintain the connection quality and link stability. This feature allows the system to overcome time-selective fading. The key feature of adaptive modulation is that it increases the range that a higher modulation scheme can be used over, since the system can flex to the actual fading conditions, as opposed to having a fixed scheme that is budgeted for the worst case conditions.

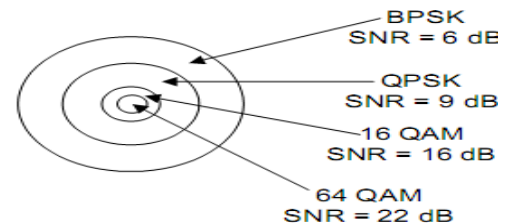

Relative cell radii for adaptive modulation

Figure. 7. Cell radii

F. Error Correction Techniques

Error correction techniques have been incorporated into WiMAX to reduce the system signal to noise ratio requirements. Strong Reed Solomon forward error correction (FEC), convolutional encoding, and interleaving algorithms are used to detect and correct errors to improve throughput. These robust error correction techniques help recover frames that may have been lost due to frequency selective fading or burst errors. This significantly improves the bit error rate (BER) performance for a given threshold level.

G. Power Control

Power control algorithms are used to improve the overall performance of the system, it is implemented by the base station sending power control information to each of the CPEs to regulate the transmit power level so that the level received at the base station is at a pre-determined level. In a dynamical changing fading environment this pre-determined performance level means that the CPE only transmits enough power to meet this requirement. The converse would be that the CPE transmit level is based on worst-case conditions. The power control reduces the overall power consumption of the CPE and the potential interference with other collocated base stations. For LOS the transmit power of the CPE is approximately proportional to its distance from the base station, for NLOS it is also heavily dependant on the clearance and obstructions.

IV. NLOS PROPAGATION MODELS

In a NLOS channel condition; the signal may have undergone scattering, diffraction, polarization changes, and reflection impairments. These factors affect the strength of the received signal. These impairments are not normally present when the transmitter and receiver have a LOS condition.

A. Nlos Models

Over the years, various models have been developed which attempt to characterize this RF environment and permit prediction of the RF signal strengths. These models, based on empirical measurements are then used to predict large-scale coverage for radio communications systems in cellular applications. These models provide estimates of path-loss considering distance between the transmitter and receiver, terrain factors, transmit and receive antenna heights, and cellular frequencies. Unfortunately none of these approaches addresses the needs of broadband fixed wireless adequately.

AT&T Wireless collected extensive field data from several areas across the United States to more accurately assess the fixed wireless RF environment. The AT&T Wireless model developed from the data has been validated against deployed fixed wireless systems and has yielded comparable results. This model is the basis of an industry-accepted model and is used by standards bodies such as IEEE 802.16. The IEEE adoption of the AT&T Wireless model is referenced as IEEE 802.16.3c-01/29r4, "Channel Models for Fixed Wireless Applications by Erceg *et al.*," and can be found on the IEEE web site [Ref 4]. The AT&T Wireless path-loss model including parameters for antenna heights, carrier frequency and terrain type is described in [Ref 5].

B. Sui Models

The Stanford University Interim (SUI) models are an extension of the earlier work by AT&T Wireless and Erceg *et al.*

It uses three basic terrain types:

- [a] Category A - Hilly/moderate-to-heavy tree density
- [b] Category B - Hilly/light tree density or flat/moderate-to-heavy tree density
- [c] Category C - Flat/light tree density

These terrain categories provide a simple method to more accurately estimate the path-loss of the RF channel in a NLOS situation. Being statistical in nature, the model is able to represent the range of path losses experienced within a real RF link.

The SUI channel models were selected for the design, development and testing of WiMAX technologies in six different scenarios, (SUI-1 to SUI-6). Using these channel models, it is then possible to more accurately predict the coverage probability that can be achieved within a base station site sector. The coverage probability estimates can then be used for further planning efforts. For example, it can be used to determine the number of base station sites necessary to provide service to a geographic area. These models do not replace the detailed site planning efforts but can provide an estimate before real planning begins. It is important to perform RF planning activities to consider specific environment factors, co-channel interference, and actual clutter and terrain effects.

C. Probability Of Coverage Prediction

In LOS conditions, coverage range is dependent on obtaining radio line of sight by ensuring Fresnel zone clearance. In NLOS conditions, there is the concept of availability of coverage, which, expressed as a percentage, represents the statistical probability that potential customers under a predicted coverage footprint can be installed. For example, a 90% probability of coverage means that 90% of the potential customers under a predicted coverage area will have sufficient signal quality for a successful install. Standardization of the WiMAX air link will allow the RF planning tool vendors to develop applications specific to NLOS predictions over time. In other words, if there are 100 potential customers that show "green" on a NLOS predicted coverage map, then 90 of those can be installed even if obstructions exist between the base station and the CPE. The RF planning and coverage prediction require to be tightly integrated with NLOS technology to allow accurate prior knowledge of which customers can be installed.

V. WIMAX COVERAGE RANGE

This section of the paper describes two likely types of base stations and their capabilities.

A standard base station with;

- A. Basic WiMAX implementation (mandatory capabilities only).
- B. Standard RF output power for a lower cost base station (vendor specific).
A full featured base station with;
- C. Higher RF output power than standard base station (vendor specific).
- D. Tx/Rx diversity combined with space-time coding and MRC reception.
- E. Sub-channeling.
- F. ARQ.

Both the standard and full-featured base stations can be WiMAX compliant, however the performance that can be achieved by each is quite different. Table 1 shows the amount of differentiation between the two different types, for a reference system configuration. It is important to understand that there are a number of options

within WiMAX that give operators and vendors the ability to build networks that best fit their application and business case. *The uplink maximum throughput in Table 1 assumes that a single subchannel is used to extend the cell edge as far as possible.

As shown the performance achievable with the full featured for indoor self-installed CPEs has a 10-fold increase in coverage area over that of the standard, Figure 8 gives a diagrammatical representation of the LOS and NLOS implications of the two different base station types.

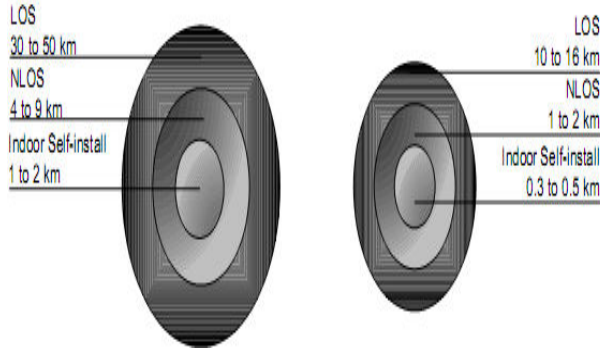

Figure. 8. Full featured and standard cell radii

An optimized network solution will likely use of a mixture of full featured and standard base stations.

VI. CONCLUSION

WiMAX technology can provide coverage in both LOS and NLOS conditions. NLOS has many implementation advantages that enable operators to deliver broadband data to a wide range of customers. WiMAX technology has many advantages that allow it to provide NLOS solutions, with essential features such as OFDM technology, adaptive modulation and error correction.

Furthermore, WiMAX has many optional features, such as ARQ, sub-channeling, diversity, and space-time coding that will prove invaluable to operators wishing to provide quality and performance that rivals wireline technology. For the first time, broadband wireless operators will be able to deploy standardized equipment with the right balance of cost and performance; choosing the appropriate set of features for their particular business model.

VII. GLOSSARY

AAS	Adaptive Antenna System
ARQ	Automatic Repeat Request
BER	Bit Error Rate
CPE	Customer Premises Equipment
ETRI	Electronics and Telecommunications Research Institute
ETSI	European Telecommunications Standards Institute
FEC	Forward Error Correction
HPi	High Speed Portable Internet
IEEE	Institute of Electrical and Electronic Engineers

ISI	Inter Symbol Interference
LOS	Line of Sight
MRC	Maximum Ratio Combining
NLOS	Non Line of Sight
OFDM	Orthogonal Frequency Division Multiplexing
RF	Radio Frequency
SUI	Stanford University Interim Models

VIII. REFERENCES

- [1]. Freeman, R, Radio System Design for Telecommunications (1-100 GHz), New York, Wiley and Sons, 1987.
- [2]. L.J. Greenstein, S. Ghassemzadeh, V. Erceg, and D.G. Michelson, "Rician K-factors in Narrowband Fixed Wireless Channels: Theory, Experiments, and Statistical models," WPMC 1999 Conference Proceedings, Amsterdam, Sept. 1999.
- [3]. J.W. Porter and J.A. Thweatt, "Microwave Propagation Characteristics in the MMDS Frequency Band," 2000 IEEE International Conference on Communications, Volume 3, pp 1578-1582.
- [4]. IEEE802.16.3c-01/29r4, "Channel Models for Fixed Wireless Applications," <http://www.ieee802.org/16>.
- [5]. Erceg, et. al., "An Empirical Based Path Loss Model for Wireless Channels in Suburban Environments," IEEE Selected Areas in Communications, Vol. 17, No. 7 July 1999.
- [6]. WiMAX's Technology for LOS and NLOS environments www.pdfio.com/k-17125.html
- [7]. Erceg, et. al., "An Empirical Based Path Loss Model for Wireless Channels in Suburban Environments," IEEE Selected Areas in Communications, Vol. 17, No. 7 July 1999.
- [8]. Oulun yliopisto, Laajakaistayhteyksien tarjonta Kainuussa, 7.10.2004 http://kafi.tutka.net/fi_tied04/LaajakaistatarjontaraporttiKainuu.pdf
- [9]. IEEE, Standards Assosiation, "IEEE 802.16e Mobile WirelessMAN (R) Standard is Official", 7.12.2005 http://standards.ieee.org/announcements/pr_p80216.html
- [10]. Viestintävirasto, Langattomat laajakaistaratkaisut, 20.6.2005
- [11]. Wave-Report, "IEEE 802.16 Tutorial", <http://www.wavereport.com/tutorials/ieee80216.htm>, page updated 30.5.2005
- [12]. Intel, "Deploying License-Exempt WiMAX Solutions", White papers, Intel 2005
- [13]. WiMAX Forum, "IEEE 802.16a Standard and WiMAX Igniting Broadband Wireless Access" White papers,
- [14]. Intel, "Understanding Wi-Fi and WiMAX as Metro-Access Solutions", White papers Wi-Fi and WiMAX Solutions 2004.